



## Code Compliance Research Report

## CCRR-0107

Subject to Renewal: 03/05/2017

Issued: 03/09/2016

Revised: 07/29/2016

Page 1 of 7

Visit [www.archtest.com](http://www.archtest.com) for current status

**Enduris Extrusions, Inc.**  
**7167 Old Kings Road**  
**Jacksonville, Florida 32219**  
**(904) 378-1884**

### 1.0 Subject

Enrail® Railing Systems:

Enrail® Series 100, Series 200, & Series 300

### 2.0 Research Scope

#### 2.1. Building Codes:

2015, 2012  
International Building Code (IBC)

2015, 2012  
International Residential Code (IRC)

#### 2.2. Properties:

Structural Performance

Durability

Surface Burning

### 3.0 Description

3.1. General – *Enrail®* Railing Systems are guards under the definitions of the referenced codes intended for use on elevated walking areas in buildings and walkways as required by the codes.

3.1.1. Guards are provided in lengths up to 10 feet (120 inches) and a maximum installed height of 42 inches (see Table 1).

3.2. Materials and Processes - Railings are an assemblage of extruded and molded components utilizing Poly Vinyl Chloride (PVC) material and aluminum reinforcements. Vinyl components are produced in white, khaki, and tan colors. All systems consist of the following components:

3.2.1. The top and bottom rails are extruded PVC profiles of various styles.

3.2.2. Balusters are extruded PVC profiles in various dimensions (see Table 2).

3.2.3. An extruded aluminum insert provides reinforcement for the top and bottom rails (see Table 1).

3.2.4. Top and bottom rails are connected to posts with molded brackets that are secured to the supports with stainless steel screws.

3.3. Supports - Railing systems can be attached to conventional wood supports or a structural PVC post sleeve installed over a steel post mount system.

3.3.1. A non-structural PVC post sleeve can be provided as a cladding over conventional 4x4 wood posts.

3.3.2. Structural 4 inch square PVC post sleeves are supported by an UltiMount™ ProSpec42 steel post mount system as permitted by Table 4.

3.3.3. Railing systems include an intermediate support block located beneath the bottom rail (see Figure 2). Railing lengths up to 8 feet have a single intermediate support located at mid-span. Railing lengths exceeding 8 feet have two intermediate supports spaced equally within the overall rail length.

For installations in One- and Two-Family Dwellings (IRC), intermediate support blocks are optional for rails up to 8 feet in length when the aluminum rail insert is utilized in the bottom rail.

### 4.0 Performance Characteristics

4.1. *Enrail®* Railing Systems have demonstrated the capacity to resist the design loadings specified in Chapter 16 of the IBC when tested in accordance with ICC-ES AC174.

4.2. Structural performance has been demonstrated for a temperature range from -20°F to 125°F.

4.3. Materials used are deemed equivalent to preservative treated or naturally durable wood for resistance to weathering effects, decay, and attack from termites.

4.4. The PVC materials used have a flame spread index not exceeding 200 when tested in accordance with ASTM E 84.

## 5.0 Installation

5.1. Installation shall be in accordance with the manufacturer's installation instructions and this report. Where differences occur between this report and the manufacturer's installation instructions, this report shall govern (see Table 1).

5.2. Railings attached to wood supports with molded brackets utilize stainless steel all-purpose screws for anchorage. The wood in the supporting structure shall have a specific gravity of 0.50 or greater (Southern Yellow Pine or better) and a minimum thickness to allow full penetration of the bracket-mounting screws. Bracket attachment shall be in accordance with Table 3.

5.3. The UltiMount™ ProSpec42 steel post mount system may be mounted in a wood deck or anchored to concrete and/or steel with approved anchors. Installation in wood decks shall be in accordance with the manufacturer's installation instructions and Figure 3.

5.3.1. The UltiMount™ ProSpec42 steel post mount system anchors used in concrete or steel installation are not within the scope of this report and are subject to evaluation and approval by the building official. Anchors must satisfy the design load requirements specified in Chapter 16 of the building code and must meet the following minimum requirements:

5.3.2. A minimum of four anchor bolts must be used and located in the four pre-drilled holes in the post base plate.

5.3.3. The anchors must have a minimum diameter equal to 5/16 inch.

5.3.4. Where required by the building official, engineering calculations and details shall be provided. The calculations shall verify that the anchorage complies with the building code for the type and condition of the supporting construction.

5.4. Compatibility of fasteners and other installation hardware with the supporting construction including treated wood is not within the scope of this report.

## 6.0 Supporting Evidence

6.1. Manufacturer's drawings and installation instructions.

6.2. Reports of testing and engineering analysis demonstrating compliance with the performance requirements of ICC-ES AC174, Acceptance Criteria for Deck Board Span Ratings and Guardrail Systems (Guards and Handrails), revised February 2014.

6.2.1. Testing in accordance with ICC-ES AC174 is deemed equivalent to ASTM D 7032-08, Standard Specification for Establishing Performance Ratings for Wood-Plastic Composite Deck Boards and Guardrail Systems (Guards or Handrails).

6.3. Quality control manual in accordance with ICC-ES AC10, Acceptance Criteria for Quality Control Manuals, dated June 2014.

## 7.0 Conditions of Use

The guard assemblies identified in this report are deemed to comply with the intent of the provisions of the referenced building codes subject to the following conditions:

7.1. Guardrails with installation heights of less than 42 inches are limited to use in One- and Two-Family Dwellings (IRC) as indicated in Table 1.

7.2. Guards with installation heights of 42 inches and regulated by the IBC or IRC are limited to exterior use in all construction types where wood is permitted in accordance with Section 1406.3 of the IBC and in One- and Two-Family Dwellings regulated by the IRC.

7.3. For jurisdictions where the 2015 IBC applies, guardrails recognized by this report are limited to Type V-B construction as specified in Section 2612.5 of the IBC.

7.4. Conventional wood supports for guards are not within the scope of this report and are subject to evaluation and approval by the building official. Supports must satisfy the design load requirements specified in Chapter 16 of the IBC and must provide suitable material for anchorage of the rail brackets. Where required by the building official, engineering calculations and details shall be provided.

7.5. Compatibility of fasteners, post mount brackets, and other metallic components with the supporting structure, including chemically treated wood, is not within the scope of this report.

7.6. *Enrail*<sup>®</sup> Railing Systems are manufactured in Jacksonville, FL in accordance with the manufacturer's approved quality control system with inspections by Architectural Testing (IAS AA-676).

### 8.0 Identification

The railing assemblies produced by Enduris Extrusions, Inc. and identified in this report shall be identified with labeling on the individual components and/or the packaging that includes the product; the manufacturer's name and/or trademark name; the identifying mark of the independent inspection agency, Architectural Testing (IAS AA-676); and the Architectural Testing Code Compliance Research Report number (CCRR-0107); and the following statement: "See CCRR-0107 at [www.ati-es.com](http://www.ati-es.com) for uses and performance levels."

### 9.0 Code Compliance Research Report Use

9.1. Approval of building products and/or materials can only be granted by a building official having legal authority in the specific jurisdiction where approval is sought.

9.2. Code Compliance Research Reports shall not be used in any manner that implies an endorsement of the product by Architectural Testing.

9.3. Reference to the Architectural Testing internet web site address at [www.ati-es.com](http://www.ati-es.com) is recommended to ascertain the current version and status of this report.

**Table 1 –Railing System Descriptions and Code Recognition**

<b><i>Enrail</i><sup>®</sup> Railing Systems</b>	<b>Railing System Components</b> (See Table 2 for Available Balusters)	<b>Maximum Size (Length x Height) <sup>1</sup></b>
Series 100	<u>Top Rail</u> : 2"x3-1/2" Rail with Alum. "H" Channel <u>Btm. Rail</u> : 2"x3-1/2" Rail with Alum. "H" Channel <sup>2</sup> <u>Top &amp; Btm. Brackets</u> : Eclipse Zinc or Eclipse PVC	8' x 42" / IBC & IRC 8' x 36" / IRC only
	<u>Top Rail</u> : 2"x3-1/2" Rail with Alum. "H" Channel <u>Btm. Rail</u> : 2"x3-1/2" Rail with Alum. "H" Channel <sup>2</sup> <u>Top &amp; Btm. Brackets</u> : Eclipse Zinc	10' x 42" / IRC only 10' x 36" / IRC only
Series 200	<u>Top Rail</u> : T-Rail with Alum. "H" Channel <u>Btm. Rail</u> : 2"x3-1/2" Rail with Alum. "H" Channel <sup>2</sup> <u>Top &amp; Btm. Brackets</u> : Eclipse Zinc or Eclipse PVC	10' x 42" / IBC & IRC 10' x 36" / IRC only
Series 300	<u>Top Rail</u> : Small Contour Rail with Contour Alum. Insert <u>Btm. Rail</u> : 2"x3-1/2" Rail with Alum. "H" Channel <u>Top Brackets</u> : Small Contour (Polycarbonate) Bracket <u>Btm. Brackets</u> : Eclipse Zinc, Eclipse PVC, or Enduris <sup>®</sup> PVC Bracket (END1092)	8' x 42" / IBC & IRC 8' x 36" / IRC only

<sup>1</sup> Railing lengths are clear distance between supports. Railing height is the installed height measured from the walking surface to the top of the top rail. Bottom rail clearance is 2-1/2".

<sup>2</sup> Alum. "H" Channel is optional in bottom rail for railing lengths 8 feet and less. When utilized, intermediate support blocks are not required for installations that do not exceed 8 feet in length and that are used in One- and Two-Family Dwellings (IRC). See section 3.3.3.

**Table 2 - Balusters**

Baluster Style
1-1/2" Square Straight Picket
1-3/8" Square Straight Picket <sup>1</sup>

<sup>1</sup> The 1-3/8" Picket is used in 36" rail heights only.

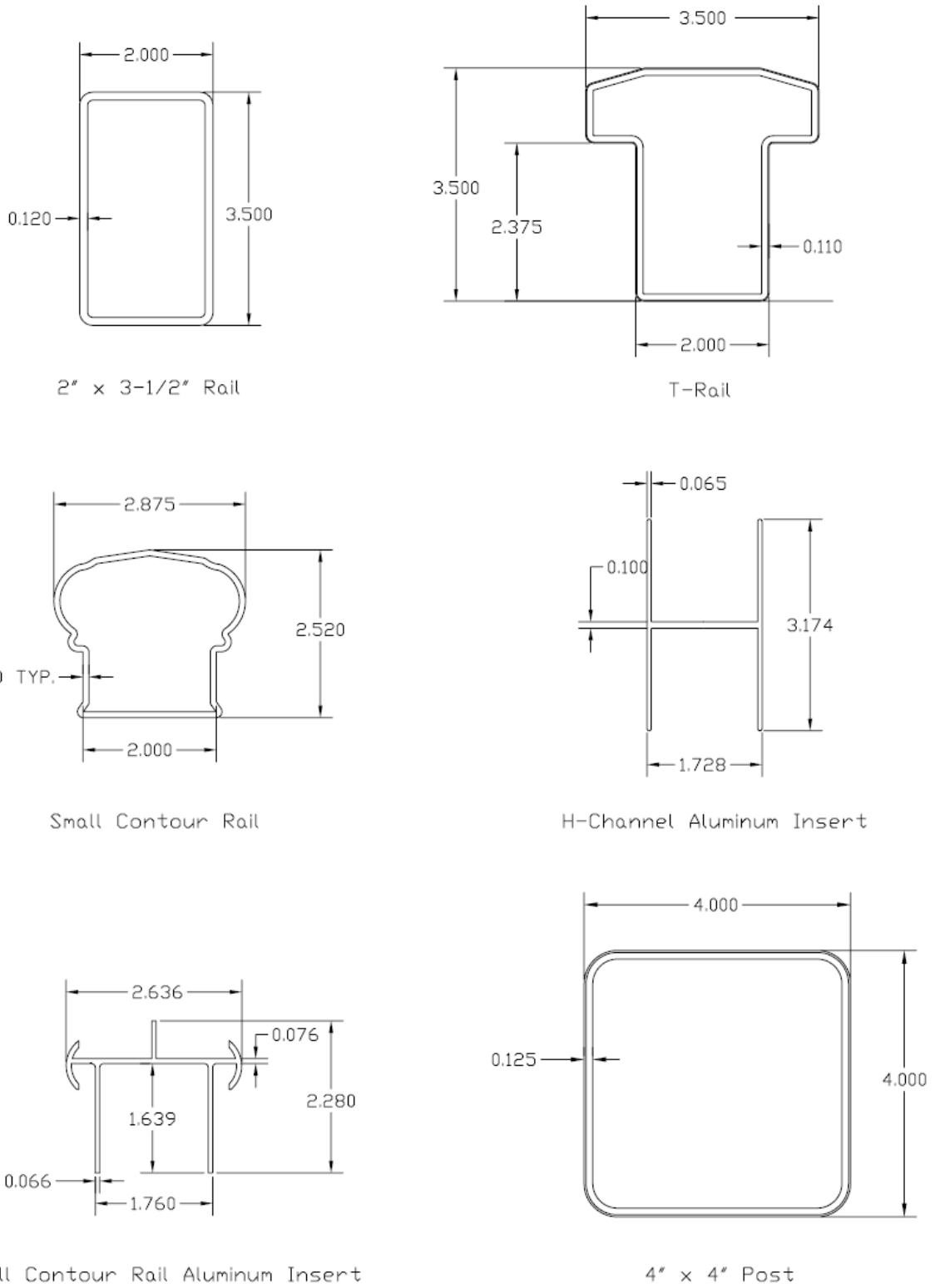
**Table 3 – Rail Bracket Fastening Schedule**

Rail – Bracket Combination	Bracket-to-Post	Rail-to-Bracket
Eclipse Zinc Bracket	(6) #12 x 2" Stainless Steel, Self-Starting Screws	(4) #10 x 1" Pan-Head Self-Tapping Screws
Eclipse PVC Bracket	(6) #12 x 2" Stainless Steel, Self-Starting Screws	(4) #10 x 1" Pan-Head Self-Tapping Screws
Small Contour Bracket (Two-Piece)	(4) #10 x 2" Stainless Steel Wood Screws	(2) #10 x 1" Stainless Steel, Self-Tapping Screws
Enduris® PVC Bracket (END1092)	(4) #10 x 3/4" Stainless Steel Wood Screws	(1) #10 x 3/4" Stainless Steel Wood Screw

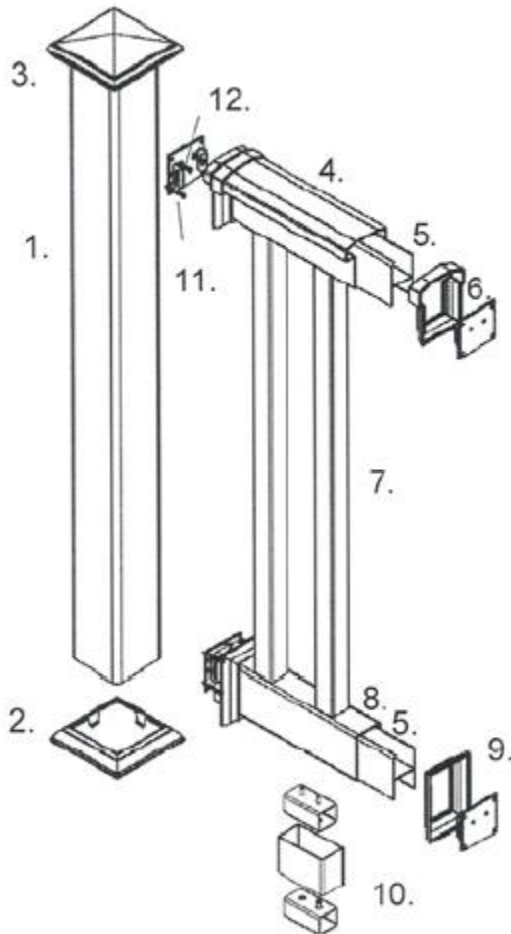
**Table 4 – Post Mounts**

Post Mounting System	Code Recognition	
	Maximum Supported Railing Length and Height <sup>1</sup>	
	IBC	IRC
UltiMount™ ProSpec42	6 ft Length 42 in Height	10 ft Length 42 in Height

<sup>1</sup> Railing lengths are clear space between supports. Railing height is installed height from walking surface to top of top rail.

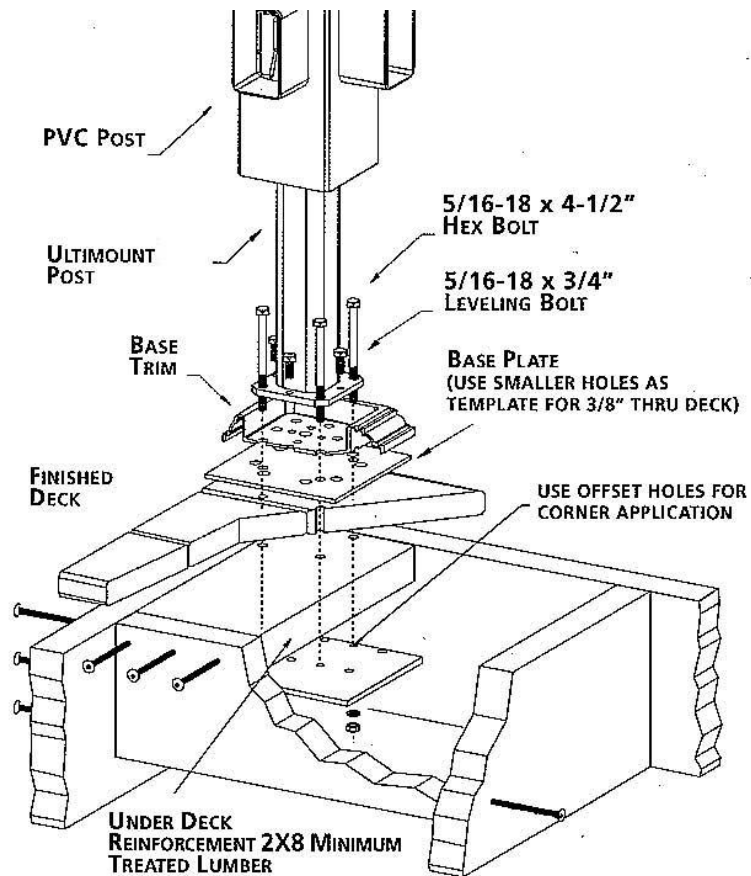


**Figure 1 - Rail and Post Profiles**



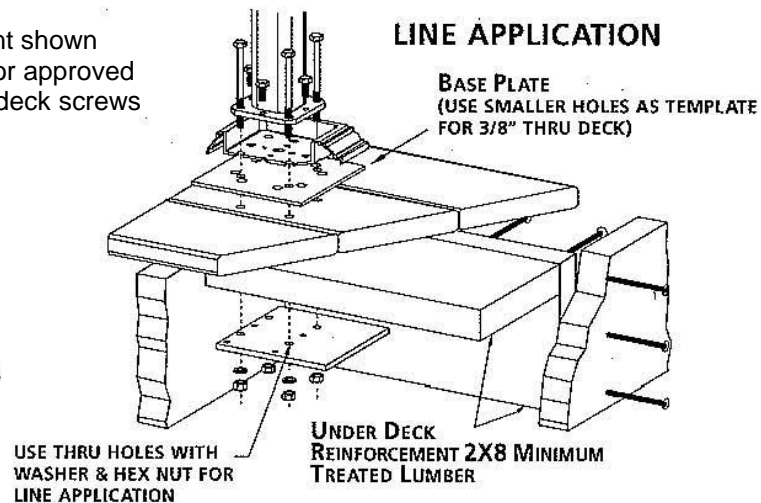
- 1. 4 inch Square PVC Post Sleeve
- 2. Base Trim
- 3. Cap Trim
- 4. PVC Top Rail (T-Rail Shown)
- 5. Aluminum Reinforcement Insert
- 6. Top Rail Bracket and Trim
- 7. PVC Balusters (Straight Pickets Shown)
- 8. PVC Bottom Rail
- 9. Bottom Rail Bracket and Trim
- 10. Intermediate Support Block
- 11. Bracket-To-Post Fasteners
- 12. Bracket-To-Rail Fasteners

**Figure 2 - Typical Rail Assembly**



**Note:**

Cross supports and reinforcement shown are 2x8 Southern Pine (treated) or approved equivalent fastened with #8 x 3" deck screws in the quantities shown.



**Figure 3 – UltiMount™ ProSpec42 Steel Post Mount System Installation in a Wood Deck**